

2015 SINGLE VIEW PRECISION CAD DRAWINGS

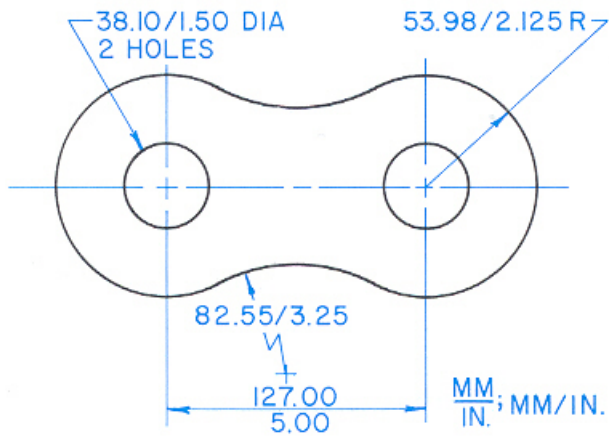

BICYCLE CHAIN LINK (FIG 3.06)

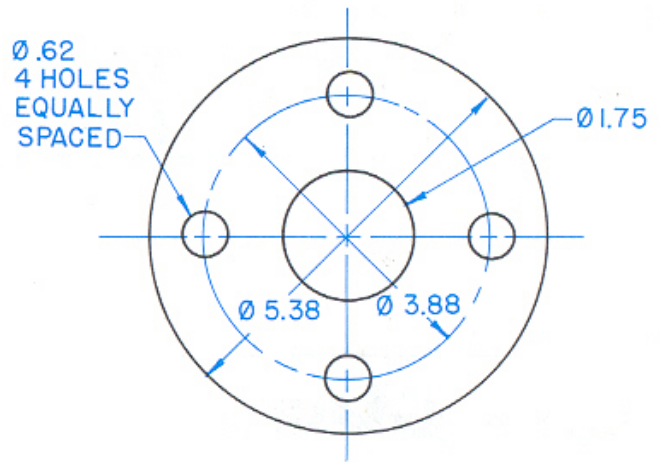

ROUND FLANGE (FIG 3.07)

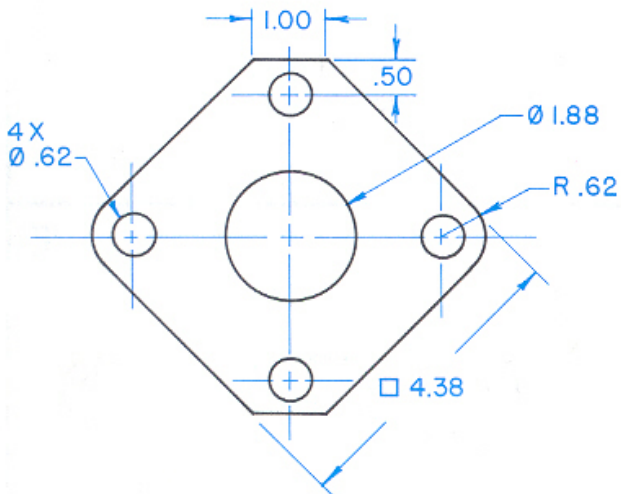

BRONZE PLATE (FIG 3.08)

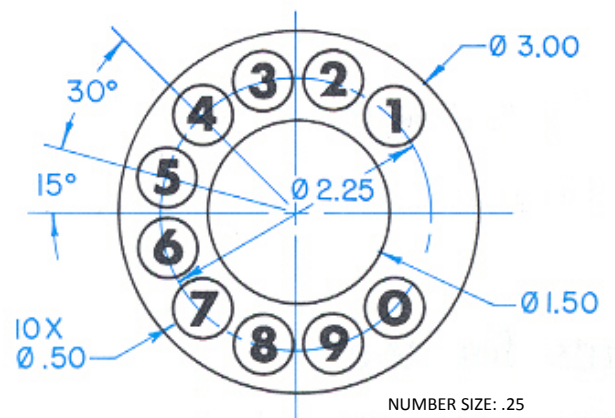

PHONE DIAL (FIG 3.09)

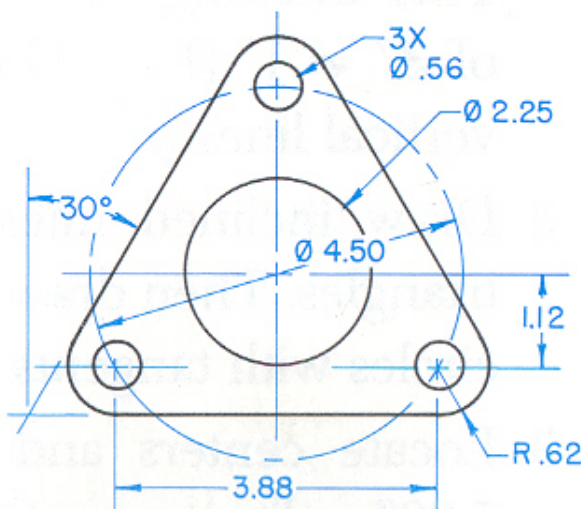

BASE PLATE (FIG 3.10)

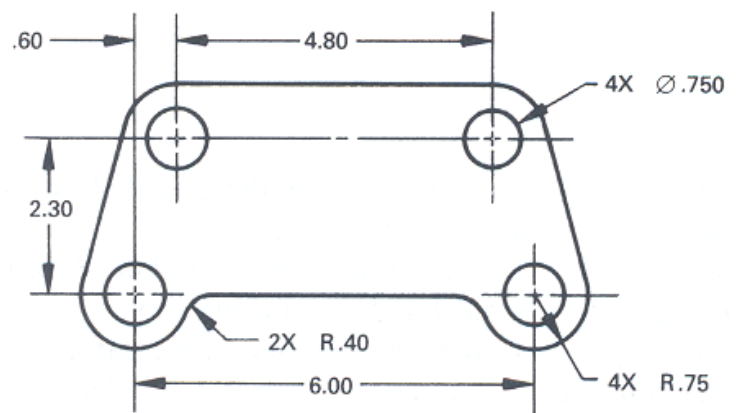

COVER PLATE (FIG 3.11)